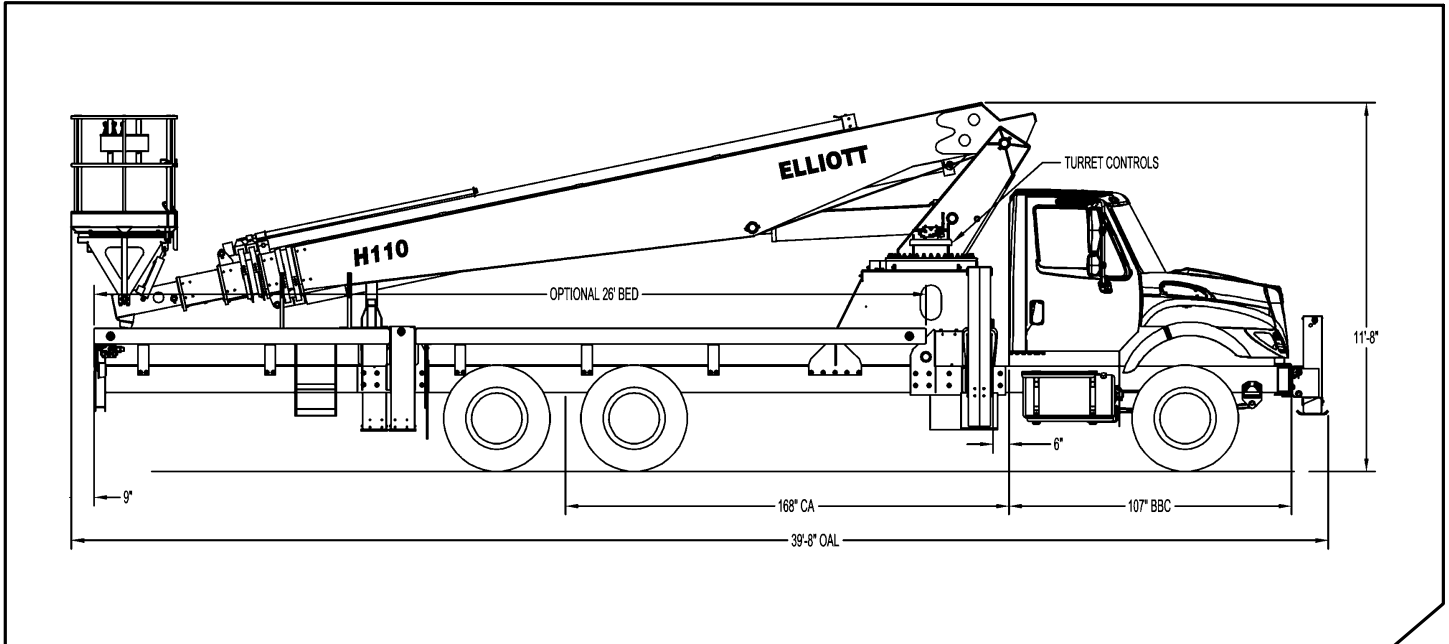

HiReach™ H110**GENERAL UNIT DESCRIPTION**

HiReach – The machine that launched an industry, the wide-ranging Elliott HiReach telescoping aerial workplatforms and cranes allow you to do more with just a single machine. From material handling and digging to basic crane and boom, the HiReach does the work of a fleet of trucks. Available with heights ranging from 35 feet to 158 feet, the HiReach comes fully equipped with standard features that are sold as options by our competition. Only Elliott features full hydraulic extension with no cables and chains. Our extension cylinder arrangement gives you the smoothest, most precise ride in the industry. What's more, all of Elliott's products can be customized to create tailor-made machines that include special platform features, pressure washers, body and tool box packages and more.

Basic unit includes base assembly supporting rotating turret, hydraulically powered rotation mechanism, oil reservoir, oil, manual hydraulic controls mounted on turret and full pressure hydraulic single stick remote control. 48" x 24" molded bucket with 2 access steps. Telescopic articulated boom design and pump. ECA "A" type hydraulically powered, individually controlled main outriggers. Power take off and pump drive, pump. Holding valves on all cylinders, fire extinguisher, remote start /shutdown at upper and lower controls, 12 volt emergency pump with switch at upper and lower controls, back up alarm, PTO hour meter, (1) body harness. Paint Hi-Reach white. Unit certified to Ansi 92.2 for Vehicle-Mounted Elevating and Rotating Aerial Devices. Working height 46 ft. Platform capacity 350 lbs.

Technical Specifications

Minimum Platform Height: 110' ground to platform floor.

Working Range: 115' max. height and 84' max. side reach.

Work Platform: Inverted "A" sub-frame with steel frame expanded metal floor and light wall tubular rails. Detachable platform support fitted to end of telescoping section with 1-1/2" diameter platform pivot shaft. Equipped with safety chain on opening and two safety lanyard attachment loops. Two safety harnesses with 72" lanyards provided. Standard rating 600 lbs.

Platform Leveling System: Hydraulic "closed" system consisting of twin platform cylinders interacting with a boom-actuated master cylinder mounted in boom support turret. System provided with factory-set relief valves to compensate for oil expansion or overload during platform leveling operation. Remote releveling controls provided in platform and at ground controls to give precise releveling capability.

Platform Controls: Three individual proportional electronic controllers meter pilot-operated, pressure-compensated modulating valves. Remote controls for boom operations from platform operate from a removable remote control box. Hi/Lo range, start/stop and engine speed toggle controls are also located at platform. Electric remote control cable extends through the electrical slip ring to cable carrier on side of boom to extending boom sections.

Lower Controls: Mounted on curbside of turret.

Outrigger Controls: Parallel open-center stack valve for lever-operated control of right and left outriggers. The outrigger valves are mounted at the rear, under each corner of the bed with roadside valve controlling roadside outriggers and curbside valve controlling curbside outriggers.

Outriggers: "H3" under-bed out-and-down main outriggers with 22 ft. spread. Additional stabilization provided by "MH" out-and-down rear outriggers and two tilting front bumper jacks.

Frame: One piece, all welded, box-type fabrication with integral outrigger mounts. Bolt-on torque frame distributes load to front of truck.

Turret: Reverse offset turret is one-piece weldment. Turret rotates on large diameter ball bearing.

Rotation: 360 degree non-continuous. Hydraulic motor drives turret through gear box.

Boom: High Strength steel plated rectangular tube sections. Assembly includes heavy-duty cylinder fittings, pivot pins, and replaceable wear pads.

Boom Extension: 3" "Piggyback" internal cylinders with 2" rods extending the two outer boom sections. Mid-boom extends with an overslung 3-1/2" trunion cylinder with 2" rod. Largest telescopic section extend with an underslung 3-1/2" external cylinder with 2" rod.

Lift: One double-acting 9" full displacement, long stroke cylinders provide smooth and stable boom elevation. Holding valve prevent boom from falling in event of hose failure.

Cylinders: All cylinders use microhoned cylinder tubing, chrome shafts, top grade packing and protective rod wipers. Cylinder-mounted holding valves provided on all load-holding cylinders.

Hoses: All high pressure hose is wire braid reinforced with a minimum safety factor of 4 to 1.

Oil Tank Capacity: 70 gallon mounted to truck frame on roadside.

Hydraulic System: Operating pressure approximately 3,000 PSI. System is parallel open center type and is equipped with liquid-filled pressure gauge. Oil is supplied to upper cylinders through hydraulic union in center of turret to cable carrier along side of the boom.

Pump: Gear type, direct mount to truck PTO. 18 GPM @ 3,000 PSI on high engine speed.

PTO: Heavy-duty, high-speed. Cable engaged from cab.

Cab Equipment: PTO cable with indicator lights installed in truck cab. Engine speed control and start/stop installed with control switches in platform remote control box and also located at lower controls. U/L approved 5:BC dry chemical fire extinguisher installed in truck cab.

Operators Manual & Video: Two copies of operation, maintenance, safety and parts manual provided with each unit. Operational and safety video provided at delivery.

Installation: Unit installed on customer's truck, painted, system and tank filled with oil, tested, inspected, certified and ready to operate.

Standard Paint: Paint Hi-Reach white, outriggers red, and bed and boxes black. Top of bed painted with black nonskid surface.

Bumper: Bureau of Motor Carrier Safety rear bumper.

Weight: Approximately 27,500 lbs. with 26' steel-floor bed less truck.

Truck Chassis Requirements: Approx. 168" C.T. RBM 2,000,000 in-lb. per rail, 14,000 lb. front axle and 48,000 lb. GVWR required. Trucks must have extended rear frame, increased cooling, heavy-duty front and rear springs, 12V electrical system with high capacity alternator, cab clearance stop/tail/backup lights, and I.D. lamps. Additional equipment to consider: front tow hook, pintle hook, mud and snow tires for off highway use. Recommended GVWR is minimum for HI-REACH with flatbed only. Contact factory when additional equipment is to be added.

Options

Bed: Length 26' (other lengths available) Width 98" with 3/16" steel tread plate floor, 6" rub rail and heavy duty cross members. Stake pockets on both sides of bed. Spray suppressant splash guard installed. Chassis stop/turn/backup lights remounted as necessary. Rear clearance and side market lights with reflectors on bed.

Heavy-Duty Hydraulic Winch: Mounted at the base of the boom for a long fleet angle and flat level spooling of cable. Option includes separate PTO, pump and valve for winch. Heavy-duty two-speed winch supplied with 300 ft. of 1/2" diameter 6x37 EIPS IWRC wire rope and swivel hook. Anti-2-block switch, 2-part hook, horn, load indicator system with digital display and certification to ANSI B 30.5 mobile cranes provided.

Platform Jib
Hydraulic, Air & 110V Lines to Platform
Welder Generators
Wood-Floor Bed
Line Bodies
Tool Storage
Full Cab Guard
Miscellaneous Options...Contact factory for details



4427 South 76th Circle
Omaha, NE 68127
Phone: 402-592-4500
Fax: 402-592-4553
Email: info@elliottequip.com
www.elliottequip.com

Notes:

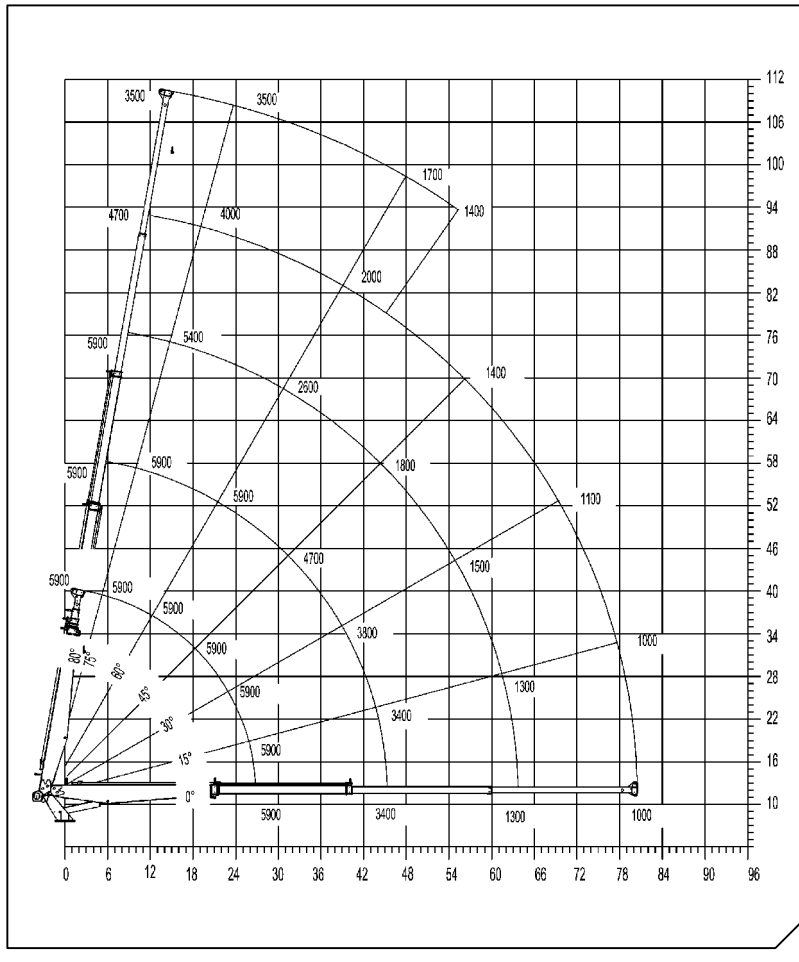

Notes:

THIS AERIAL DEVICE IS NON-INSULATING. IT PROVIDES NO ELECTRICAL PROTECTION. CONTACT WITH OR INADEQUATE CLEARANCE TO AN ENERGIZED LINE OR APPARATUS IS AN ELECTROCUTION HAZARD.