

BoomTruck™ 2895

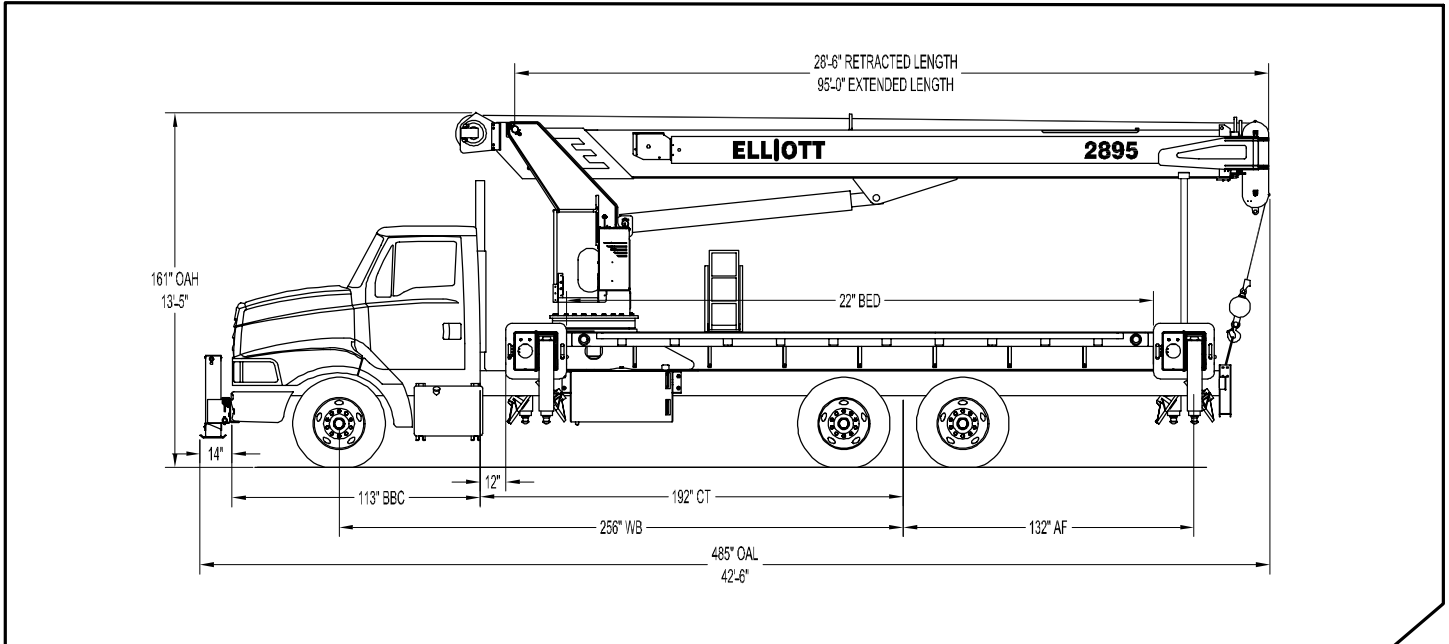

GENERAL UNIT DESCRIPTION

BoomTruck – When it comes to design and engineering, Elliott’s BoomTruck is generations apart from the traditional crane—making it ideal for the exacting demands of today’s job sites. With an industry-leading 18-ton capacity crane equipped with the 38’ boom option, the BoomTruck delivers high performance with increased efficiency—from its high-speed outrigger set-up, boom extension and retraction to its high-pull winch. Plus our BoomTruck requires very little maintenance thanks to its layaway hoist, 10 percent fewer fittings than competitor models and the industry’s best warranty. That gives you time to enjoy operator amenities like the built-in cup holders and 12-volt charger on the operator console.

Basic unit includes base assembly supporting front mounted rotating turret, hydraulically powered rotation mechanism, oil reservoir, oil, and dual operator console with levers linked to manual hydraulic control valve mounted to pedestal. Base mounted "A" frame link type outriggers hydraulically powered, individually controlled main outriggers. Under frame mounted outriggers for rear stabilization. High strength steel three section hydraulic and cable telescoping boom with one double acting 7" lift cylinder. Boom can be stowed over cab to increase payload & eliminate payload to boom interference on bed. Load Moment Indicator System with display and hydraulic function lockout for load capacities. Power take off and pump drive, pressure gauge, three-section gear pump and holding valves on all cylinders. Control console is equipped with Anti-2-Block system, engine start/stop, variable speed foot throttle, horn, winch burst of speed, and outrigger motion alarm. Additional equipment includes triangle reflector kit, backup alarm, and fire extinguisher. Paint BoomTruck white, outriggers red and bed and boxes black. Installed on chassis, tested and ready to operate. Unit certified to ANSI B30.5 for Mobile and Locomotive cranes.

Technical Specifications

Crane Capacity: 56,000 pounds at five feet load radius.

Maximum Tip Height: 107' height (152' with optional 45' jib)

Control Console: Rotating turret single operator control station equipped with four single axis control levers for the main crane controls. Operator station includes LMI display, bubble level gauge, engine start/stop switch, signal horn button, variable speed throttle switch, lifting capacity chart, range diagram chart, boom angle indicator, system pressure gauge, 12V DC power source, and cup holder. Independent ground level electric operated outrigger controls.

Boom: Four-section fully proportional, high strength steel plated rectangular tube sections. A maximum boom tip height of 107 feet mounted on a truck. The boom nose contains one floating upper sheave and three lower sheaves. Assembly includes heavy-duty cylinder fittings, pivot pins, and replaceable wear pads.

Winch: Mounted at the base of the boom for a long fleet angle and flat level spooling of cable. Winch is driven by a planetary reducer and powered by a hydraulic motor. Burst-of-speed winch provides increased line speed. The winch brake is spring applied, pressure release design. Supplied with 425' of 9/16" diameter rotation resistant wire rope with a single line pull of 8,900 pounds, and a downhaul ball with swivel hook for single part line.

Load Moment Indicator System: LMI system senses hoist cylinder pressures, boom length and boom angle with hydraulic function lockout. The display console is equipped with an integrated bar graph showing crane utilization, boom angle or boom length, a mode select controls for main boom and jib operation, and an anti-two block with an audio/visual warning and shut-off functions to limit hook-boom point contact.

Outriggers: Two sets of out and down overframe outriggers with 20 foot span. Outriggers are configured for full span or mid span operation. Outriggers equipped with ball socket aluminum removable pads that stow on vertical outrigger legs.

Frame: Full length, all welded rigid 4-plate design sub-frame. Sub-frame allows for bolt-on addition 22' bed wings, with top plate of subbase serving as portion of the bed deck, to form a three-piece bed.

Turret: Turret is one-piece weldment. Turret rotates on large diameter ball bearing.

Rotation: Hydraulic motor drives turret through double reduction planetary swing drive for 372-degree non-continuous rotation. The swing drive system has a spring applied, pressure release brake.

Boom Extension: Incorporates a 2-stage hydraulic extension cylinder, attached to the largest boom section, with a proportional cable extension system driving the outermost sections.

Lift: One double acting full displacement, long stroke cylinder provides smooth and stable boom elevation. Holding valve prevents boom from lowering in event of hose failure.

Cylinders: All cylinders use microhoned cylinder tubing, chrome shafts, top grade packing and protective rod wipers. Cylinder-mounted holding valves provided on all load-holding cylinders.

Hoses: All high-pressure hose is wire braid reinforced with a minimum safety factor of 4 to 1.

Oil Tank Capacity: 120 gallon mounted to truck frame on roadside.

Hydraulic System: Equipped with cable-shift PTO, piston pump, SAE O-ring face seals on pressure lines, and a 10-micron return line filter. The control valve distributes all flow to the hoist system, swing circuit, and other crane functions. System is closed center type.

Cab Equipment: PTO cable and switch with indicator light installed in truck cab. U/L approved 5:BC dry chemical fire extinguisher installed in truck cab.

Operator Manual: One copy of operation, maintenance, safety and parts manual provided with each unit.

Installation: Unit installed on customer's truck, painted, system and tank filled with oil, tested, inspected, certified and ready to operate.

Standard Paint: Paint BoomTruck white, outriggers red, and bed and boxes black.

Bumper: Bureau of Motor Carrier Safety rear bumper.

Weight: Approximately 26,700 lbs. with 22' steel floor bed, less truck.

Truck Chassis Requirements: Approximately 192" C.A., 18,000 lb. front axle, 34,000 lb. rear axle, and 52,000 lb. GVWR required. Trucks must have extended rear frame, increased cooling, heavy duty front and rear springs, 12V electrical system with high capacity alternator, cab clearance stop/tail/backup lights, and I.D. lamps. Additional equipment to consider: front tow hook, pintle hook, mud and snow tires for highway use. Recommended GVWR is minimum for BoomTruck with flatbed only. Contact factory when additional equipment is to be added.

Options

45' telescopic jib

Radio remote control crane operation

Radio operated remote for outrigger setup

Open seated controls and cab (rear mount)

Outrigger interlock system to allow working over one side of crane

Hook block for 2/3-part line load

Hook block for 4 part line load

Rear mount

Tool boxes

Front jack for 360 degree crane operation

Steel gravity level platform

Continuous rotation

Oil Cooler

Miscellaneous Options Contact factory for details



4427 South 76th Circle

Omaha, NE 68127

Phone: 402-592-4500

Fax: 402-592-4553

Email: info@elliottequip.com

www.elliottequip.com

Notes:

Notes:

THIS AERIAL DEVICE IS NON-INSULATING. IT PROVIDES NO ELECTRICAL PROTECTION. CONTACT WITH OR INADEQUATE CLEARANCE TO AN ENERGIZED LINE OR APPARATUS IS AN ELECTROCUTION HAZARD.